

M-Bar

Electromechanical road barrier system for control of road access

For bars up from 3 to 7 m.

24 Vdc gear motor with built-in control unit.

Simplified programming: control unit with display and joystick to make setting operating parameters even faster.

The control unit has an output to power 24 Vdc devices and two inputs to control loop detectors with the LP21 and LP22 accessories.

Modular: bars are easily assembled using the aluminium expansion joint.

Possibility for intelligent control of two opposing automations thanks to **"master/slave" function.**

Strength and reliability: tough steel structure, new robust balancing springs guaranteed to 2,000,000 cycles and elliptical section shaft with high resistance to gusts of wind.

Optional flashing or traffic light can be integrated in cover.

Encoder movement control and electromechanical limit switches.

More comfort and safety in programming and maintenance phases: the separate enclosures for electronics and mechanics protect internal parts from potential risks.

Rapid and easy access to the control unit located in the upper section of the barrier body.

Simple fixture of the completely concealed photocells onto the specially designed seats on the barrier body.

More safety and reliability: obstacle detection and monitoring of motor absorption during automation movement.

Automatic fault diagnostics during operation with consequent signalling of fault type through specific flash sequences.

Provision for connection of latest generation optical and resistive sensitive edges (with 8.2 KOhm resistance).

Energy saving: the system sets to standby when not in use to save power.

No black out: with the optional batteries (PS224) housed inside the gear motor.

Release from side with metal key: can be installed on either side.

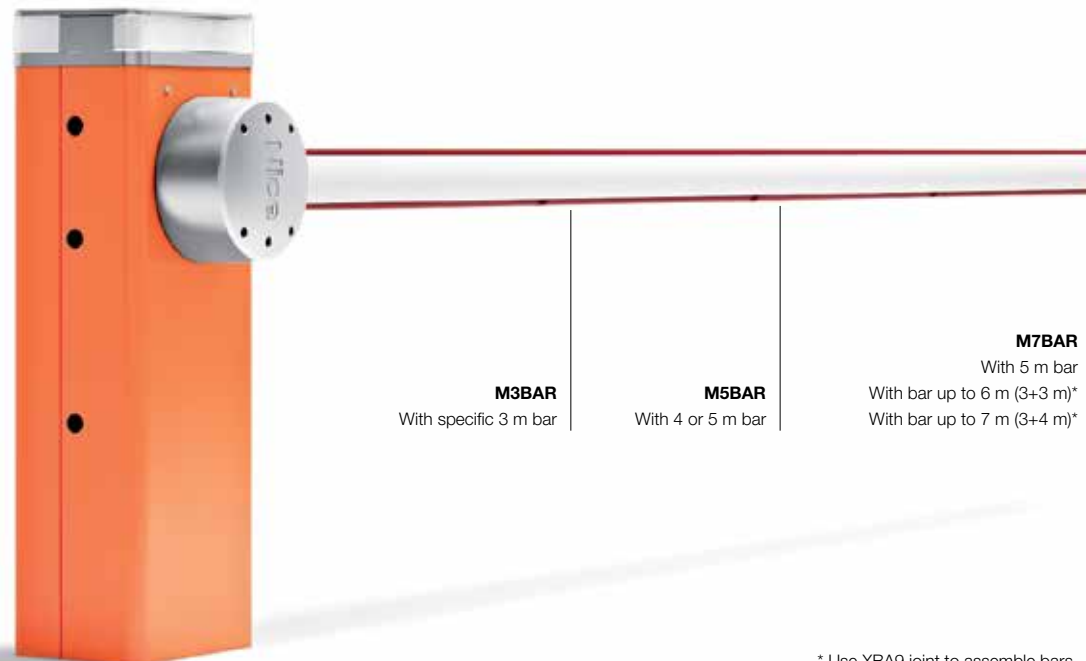

M3BAR
With specific 3 m bar

M5BAR
With 4 or 5 m bar

M7BAR
With 5 m bar
With bar up to 6 m (3+3 m)*
With bar up to 7 m (3+4 m)*

* Use XBA9 joint to assemble bars.

DIMENSIONS

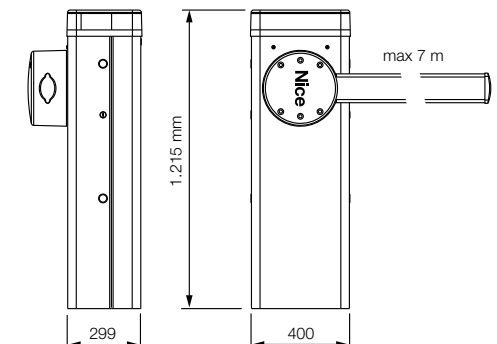

COMMON ACCESSORIES



IBT4N
Interface for connecting the O-View programming unit.
Pc./Pack 1



IT4WIFI
Smart Wi-fi interface to manage gates and garage doors by smartphone. (Not compatible with the Solemyo kit and battery backup.)
Pc./Pack 1



BCU1
Spare control unit.
Pc./Pack 1



PS224
24 Vdc buffer batter.
Pc./Pack 1



LP21
Magnetic loop detector 1 channel.
Pc./Pack 1



LP22
Magnetic loop detector 2 channels.
Pc./Pack 1



SOLEMYO KIT
The solar power to automate gates, garage doors or barrier gates.
See page 140.

IN ORDER TO HAVE A FULLY FUNCTIONAL BARRIER GATE OPERATOR SYSTEM:

1. CHOOSE THE GEAR MOTOR

2. SELECT THE BAR

3. COMPLETE THE SYSTEM WITH THE OPTIONAL ACCESSORIES

TECHNICAL SPECIFICATIONS

With bar up to 3 m, irreversible 230 Vac, 24 Vdc motor, with foundation plate:

Code	Description
M3BAR	With steel case with protective cataphoresis treatment and paint finish. For intensive use
M3BARI	With stainless steel case

With bar up to 4 or 5 m, irreversible 230 Vac, 24 Vdc motor, with foundation plate:

Code	Description
M5BAR	With steel case with protective cataphoresis treatment and paint finish. For intensive use
M5BARI	With stainless steel case

With bar up to 5, 6 or 7 m, irreversible 230 Vac, 24 Vdc motor, with foundation plate:

Code	Description
M7BAR	With steel case with protective cataphoresis treatment and paint finish
M7BARI	With stainless steel case

Code	M3BAR	M3BARI	M5BAR	M5BARI	M7BAR	M7BARI
ELECTRICAL DATA						
Power supply (Vac 50/60 Hz)				230		
Power supply (Vdc)				24		
Absorption (A)	1.3		1.1		1.1	
Power (W)	150		110		110	
PERFORMANCE DATA						
Speed min. ÷ max. (s)	1.5 ÷ 4		3 ÷ 6		6 ÷ 10	
Torque (Nm)	100		200		300	
Work cycle (cycles/hour)	600		450		200	
DIMENSIONAL AND GENERAL DATA						
Protection level (IP)				54		
Working temp. (°C Min/Max)				-20 ÷ +55		
Dimensions (mm)				400x299x1215 h		
Weight (kg)				80		85

COMPATIBILITY TABLE WITH CONTROL SYSTEMS AND ACCESSORIES

Code	receiver		transmitter				photocells								flashing light						
	Built-in*	OX1	ERA INTI	ERA ONE	ERA FLOR	NICEWAY	EPS	EPM	EPL	EPSB	EPMB	EPLB	EPMOV	EPMDR	F210	FT210	F210B	FT210B	ELAC	ELDC	WLT
M3BAR / M3BARI		•	•	•	•	•				•	•	•	•	•					•	•	•
M5BAR / M5BARI		•	•	•	•	•				•	•	•	•	•					•	•	•
M7BAR / M7BARI		•	•	•	•	•				•	•	•	•	•					•	•	•

* Radio receiver incompatible with Opera system

Accessories M-Bar

COMMON ACCESSORIES



XBA13
Rubber impact protection strip. Length 1 m.

Pc./Pack 9



WA10
Red adhesive reflector strips.

Pc./Pack 24



XBA8
Integrable traffic light.

Pc./Pack 1



XBA7
Integrable flashing light.

Pc./Pack 1



XBA16
Anchorage base with clamps.

Pc./Pack 1



WA11
Adjustable stand for bars.

Pc./Pack 1

BARS FOR M3BAR

ACCESSORIES FOR M3BAR



XBA15
White paint-finished aluminium bar 69x92x3150 mm.

Pc./Pack 1



XBA4
Indicator lights for click fixture on upper or lower side of bar. Length 4 m.

Pc./Pack 1



XBA10
Pivot joint for bars up to 4 m.

Pc./Pack 1



XBA11
Joint for bars (from 1950 mm to 2400 mm).

Pc./Pack 1

BARS FOR M5BAR



XBA14
White paint-finished
aluminium bar
69x92x4150 mm.

Pc./Pack 1



XBA5
White paint-finished
aluminium bar
69x92x5150 mm.

Pc./Pack 1

ACCESSORIES FOR M5BAR



XBA4
Indicator lights for click
fixture on upper or
lower side of bar.
Length 4 m.

Pc./Pack 1



XBA6
Indicator lights for click
fixture on upper or
lower side of bar.
Length 6 m.

Pc./Pack 1



XBA10
Pivot joint for bars up
to 4 m.

Pc./Pack 1



XBA11
Joint for bars (from
1950 mm to 2400 mm).

Pc./Pack 1



WA12
Mobile stand for bars
- new fully reinforced
version.

Pc./Pack 1



WA13
Aluminium rack up to
2 m.

Pc./Pack 1

BARS FOR M7BAR



XBA15
White paint-finished
aluminium bar
69x92x3150 mm.

Pc./Pack 1



XBA14
White paint-finished
aluminium bar
69x92x4150 mm.

Pc./Pack 1



XBA5
White paint-finished
aluminium bar
69x92x5150 mm.

Pc./Pack 1



XBA9
Expansion joint.

Pc./Pack 1



XBA6
Indicator lights for click
fixture on upper or
lower side of bar.
Length 6 m.

Pc./Pack 1



XBA18
Indicator lights for click
fixture on upper or
lower side of bar.
Length 8 m.

Pc./Pack 1



WA12
Mobile stand for bars
- new fully reinforced
version.

Pc./Pack 1



WA13
Aluminium rack up to
2 m.

Pc./Pack 1