

# Hyke HS

For hi-speed automation of swing gates with leaves up to 3 m or 270 Kg

**Ideal for residential applications even with large columns.**

24 Vdc electromechanical gear motor with articulated arm, surface mounted, with magnetic encoder.

🕒 **Ideal for intensive use and quick manoeuvres:** 90° opening in about 10\* seconds.

## 🇺🇸 Oz Kit

- Oz Kit 1**
- motor x 1
  - receiver x 1
  - two channel remote x 2
- Oz Kit 2**
- motor x 2
  - receiver x 1
  - two channel remote x 2

**Ultra-powerful and reliable:** thanks to the torque of 500 Nm and encoder technology, for millimetric precision and reliability.

**Safe movement:** dual technology obstacle detection.

**Sturdy:** thanks to the housing in aluminium with polyester paint finish, resistant to atmospheric agents.

**Two irreversible 24 Vdc versions** with limit switches on opening and closing: with built-in control unit (HK70240) and without control unit (HK7224).

**Practical and quick installation:** the articulated arm is adjustable in length for maximum flexibility.

**Simple and precise limit switch adjustment:** mechanical stops and micrometric adjustment screws.

**No black out:** with the optional batteries (PS124) housed inside the gear motor.

**Built-in control unit (HK7024):**

- simple programming, by means of a single key;
- automatic memorisation of limit switches on opening and closing with self-learning function;
- automatic fault diagnostics;
- programming of pause time;
- pedestrian pass door;
- deceleration on opening and closing;
- obstacle detection with dual technology;
- provision for connection of latest generation resistive sensitive edges.

\* Considering standard installation, excluding acceleration and deceleration.



## COMMON ACCESSORIES



**IT4WIFI**  
Smart Wi-fi interface to manage gates and garage doors by smartphone. (Not compatible with the Solemyo kit and battery backup.)



**HKA2**  
Spare control unit for HK7024HS,  
Pc./Pack 1



**PS124**  
24 V battery with integrated battery charger.  
Pc./Pack 1



**PLA10**  
Vertical 12 V electric lock.  
Pc./Pack 1



**PLA11**  
Horizontal 12 V electric lock.  
Pc./Pack 1



**KIO**  
Key-operated selector switch for low voltage contacts, with release mechanism for metal cord.  
Pc./Pack 1



**KA1**  
6 m cable release kit for KIO.  
Pc./Pack 1



**TS**  
Signboard.  
Pc./Pack 1



**SOLEMYO KIT**  
The solar power to automate gates, garage doors or barrier gates.

See page 140.

## TECHNICAL SPECIFICATIONS

Code	Description	Pack/Pallet
<b>HK7024HS</b>	Irreversible 24 Vdc, fast, with magnetic encoder, complete with articulated arm and built-in control unit	12
<b>HK7224HS</b>	Irreversible 24 Vdc, fast, complete with articulated arm without control unit	12

Code	HK7024HS	HK7224HS
<b>ELECTRICAL DATA</b>		
Power supply (Vac 50/60 Hz)	230	-
Power supply (Vdc)	-	24
Absorption (A)	1.5	6
Power (W)	300	140
<b>PERFORMANCE DATA</b>		
Speed (rpm)	>> 2 <<	
Torque (Nm)	500	
Work cycle (cycles/hour)	40	
<b>DIMENSIONAL AND GENERAL DATA</b>		
Protection level (IP)	54	
Working temp. (°C Min/Max)	-20 ÷ +50	
Dimensions (mm)	290x210x320 h	
Weight (kg)	10.5	9.5

## UTILISATION LIMITS

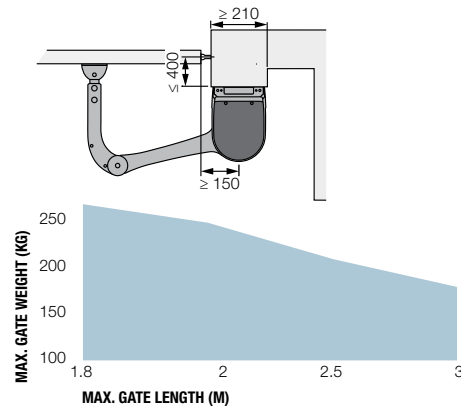

The shape, the height of the gate and the weather conditions can considerably reduce the values shown in the graph to the side.

## DIMENSIONS

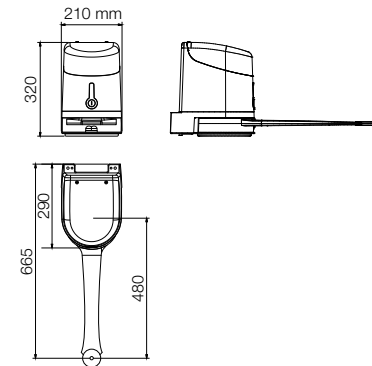

## COMPATIBILITY TABLE WITH CONTROL SYSTEMS AND ACCESSORIES

Code	receiver		transmitter					photocells						flashing light						
	Built-in*	OXI	ERA INTI	ERA ONE	ERA FLOR	NICEWAY	EPS	EPM	EPL	EPFB	EPMB	EPLB	EPWOW	F210	F210	F210B	F210B	ELAC	ELDC	WLT
<b>HK7024HS</b>		•	•	•	•	•					•	•	•			•			•	•

\* Radio receiver incompatible with Opera system